

A Higher Level of Performance



Data Sheet

Gladiator

Acoustic Switch & Auto Spray Cleaner

Non-contact Self Cleaning Blocked Chute Detection



For more information, please visit >
www.hawkmeasure.com

Overview

Gladiator Acoustic Switch Series



Acoustic Cleaning



Principle of Operation

The Gladiator Acoustic Switch uses Acoustic Wave technology in a new Sender / Receiver form for blocked chute detection and anti collision for heavy machinery. The Gladiator Amplifier powers two AW Transducers which use special HAWK developed software where both units pulse and receive each other's Acoustic echoes. When the path between the Transducers is blocked, the units immediately detect the presence / absence change of the return signal and trigger a communications relay for indication or control purposes. The Transducers work both together and independently to detect pulse interference giving twice the application security.

HAWK's Acoustic Wave Transducers are self cleaning. The Acoustic Switch is designed for continuous operation in dusty, wet environments where other technologies fail. The power of each pulse (pressure wave) blows the water, moisture and build-up off the face of the diaphragm.

Typical Uses

- Blocked chute detection in wet or dry environments
- Wet screen blocked chute detection
- Nucleonic / tilt switch replacement
- High level alarm / Low level alarm
- Truck / machine detection (ROM bins, Primary Crusher Dump Pockets)
- Sewage sludge handling
- Point level switch.

Function

The Gladiator Acoustic Switch can be used for blockage detection, barrier detection, machine detection / protection and point level measurement, and detection of objects or material between two points.

Primary Areas of Application

- Brewing
- Cement
- Chemical
- Fertilizer
- Food & Beverage
- Glass
- Mining & Metals
- Packaging
- Paper
- Pharmaceutical
- Plastics
- Refining
- Sugar
- Water & Wastewater
- Sewage Sludge
- Power Generation (coal fired).

Features

- No contact with the product required
- Self cleaning transducers
- Heavy duty titanium version available
- Designed for dusty, wet environments
- LCD setup / diagnostics on remote amplifier
- Simple '1-minute' setup
- 2 Relay outputs
- Adjustable ON and OFF delays
- Remote 3G connection option & support
- Remote amplifier to sensor separation up to 500 meters (1640ft).

Typical Applications

Gladiator Acoustic Switch Series

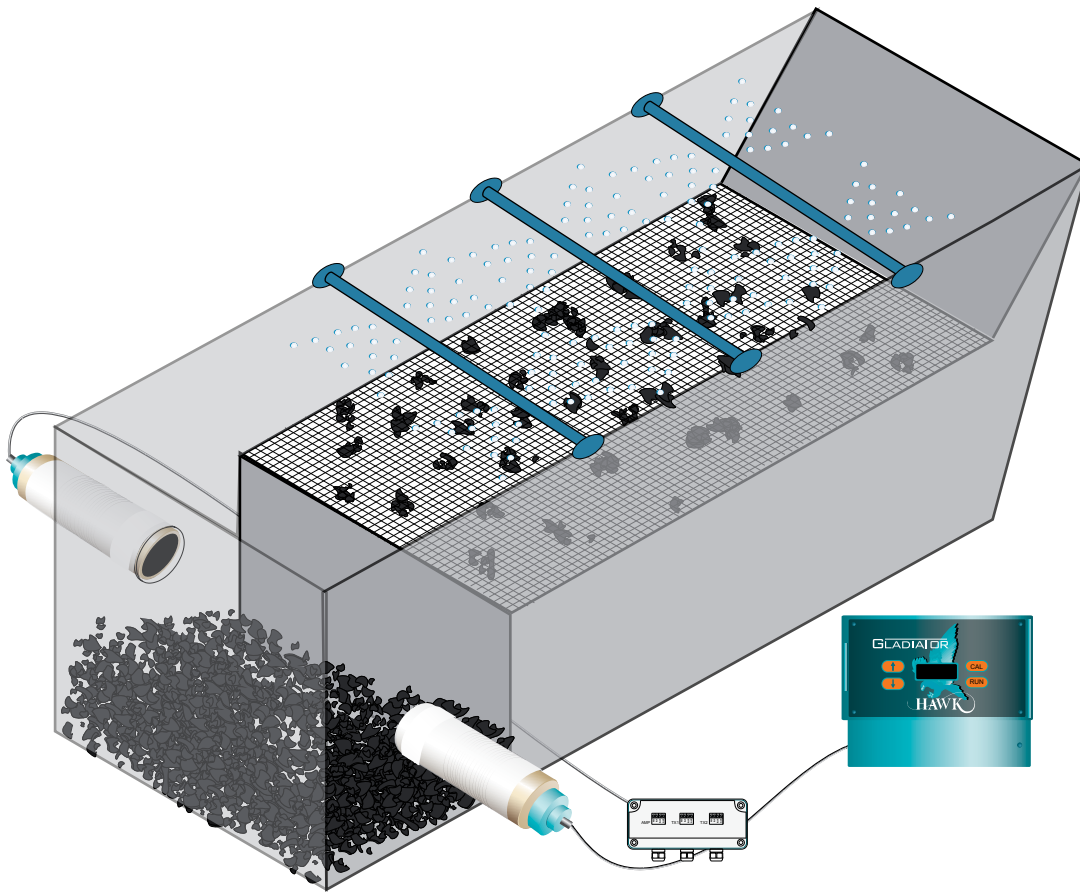

Our on-ongoing commitment is to provide **Industry Leading Technology** and **Cost Effective Solutions.**



**Wet Screens
Blocked Chute Detection -
Water Sprays**



ROM Bins Blocked Chute Detection - Wet / Dry Product / Truck Detection / Water Sprays



Typical Applications

Gladiator Acoustic Switch Series



Process Protection - Blocked Chute

Bulk Solids

- Material flow blockage detection
- Designed for wet & dusty environments
- Self cleaning Transducers dislodge & prevent build up
- Heavy duty Titanium version for product impact resistance
- Apron Feeder
- Reclaim conveyor blocked
- Jam protection
- Slurry
- Sludge product

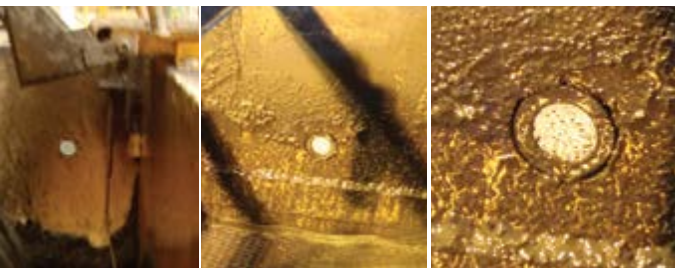
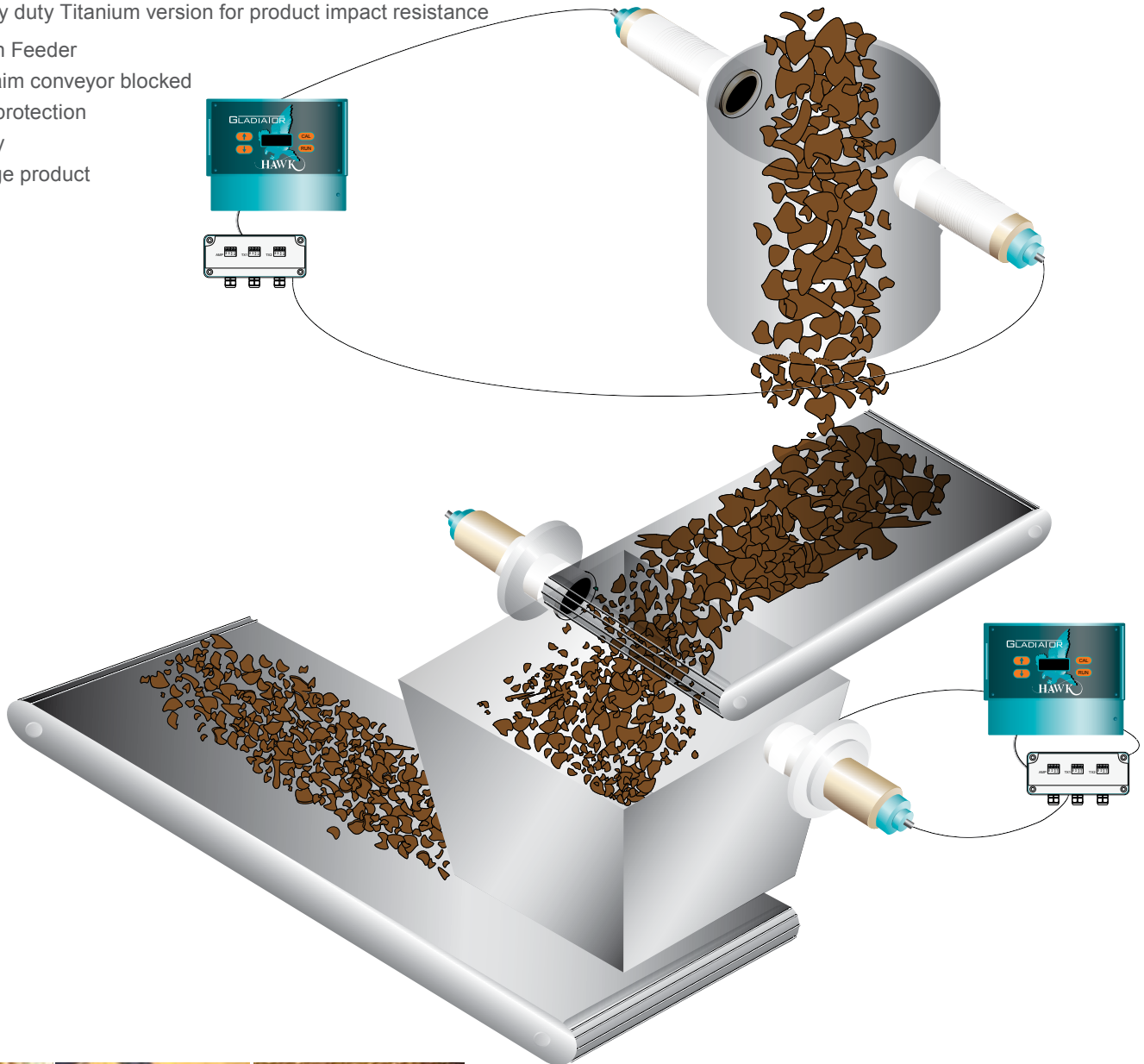

Dimensions

Gladiator Acoustic Switch Series



Remote Amplifier

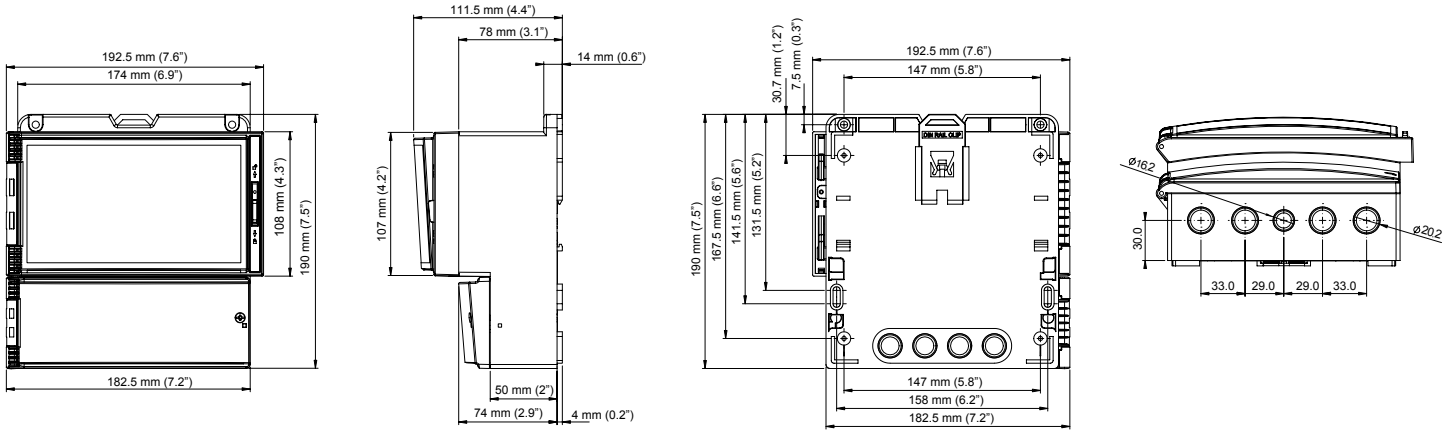

Remote Transducer

With GAWSLV-3-X and FA4A-4 Flange

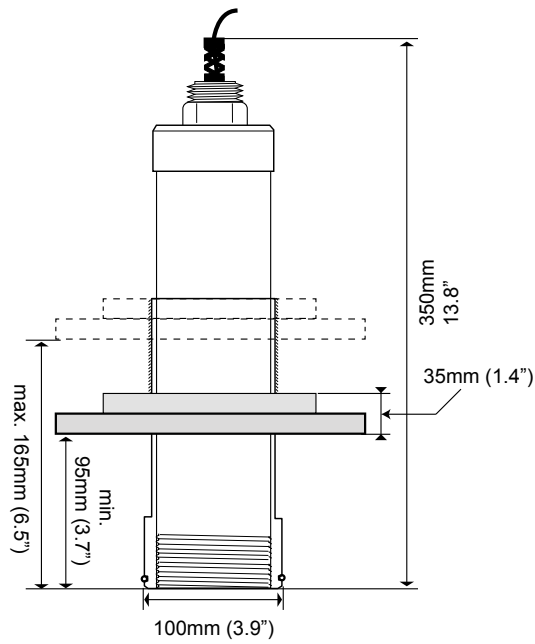

Remote Transducer with Spray Cleaner

With FA4A-4-ASC Flange

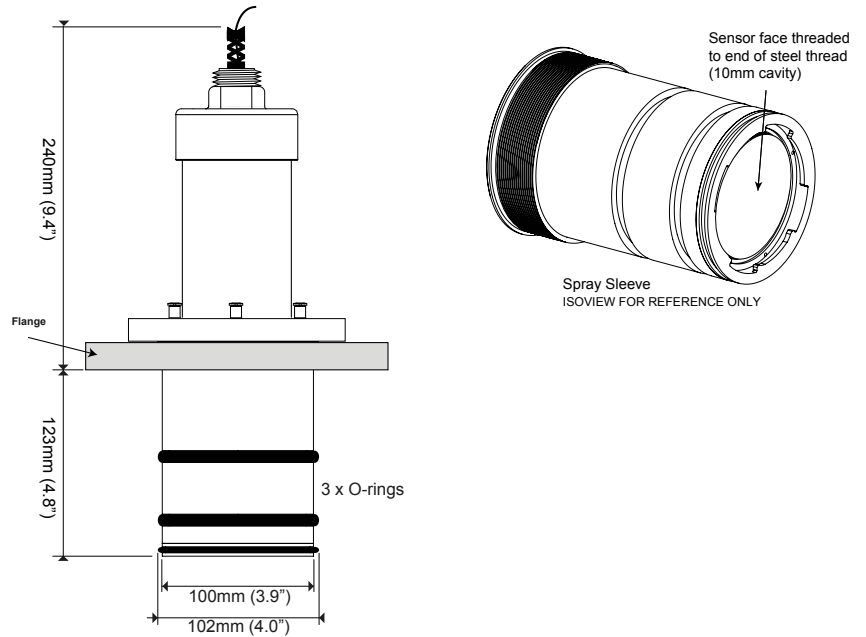

Mounting Flange

STANDARD 4" ANSI FLANGE DIMENSIONS

SIZE	FLANGE TYPE	A (PCD) mm in.	B (OD) mm in.	C (Hole) mm in.	No. Holes
4"	FA4	190.5 7.5	228 9.0	19 0.75	8

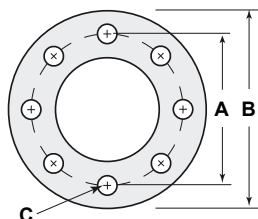

Dimensions / Mounting

Gladiator Acoustic Switch Series



AWRT-JB Junction Box

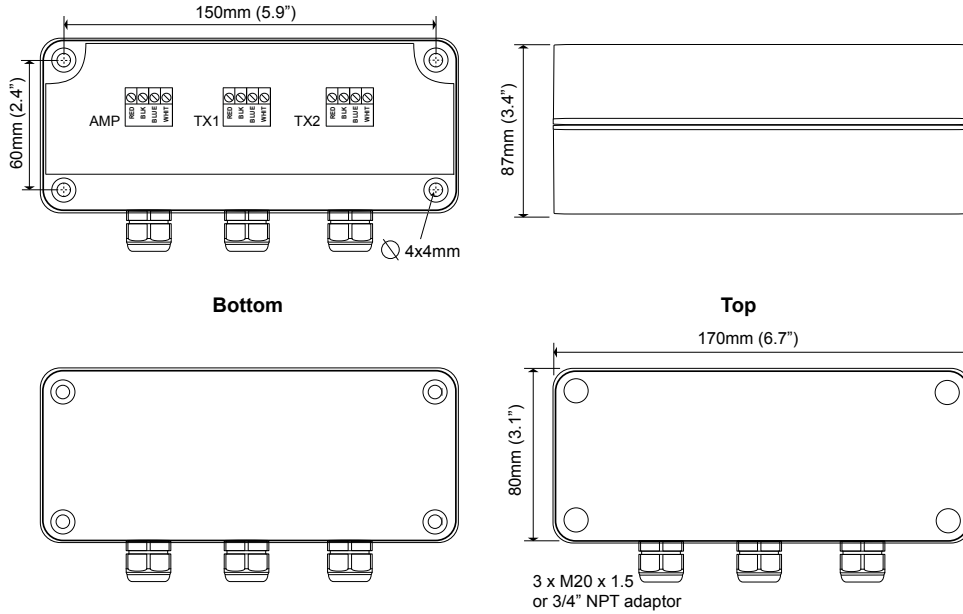

Typical Mounting

With GAWSLV-3-X UHMW sleeve and FA4A-4 Flange

With Spray Cleaner and FA4A-4-ASC Flange

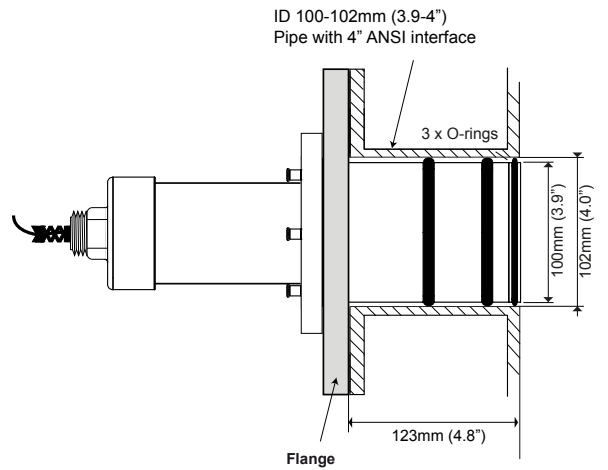
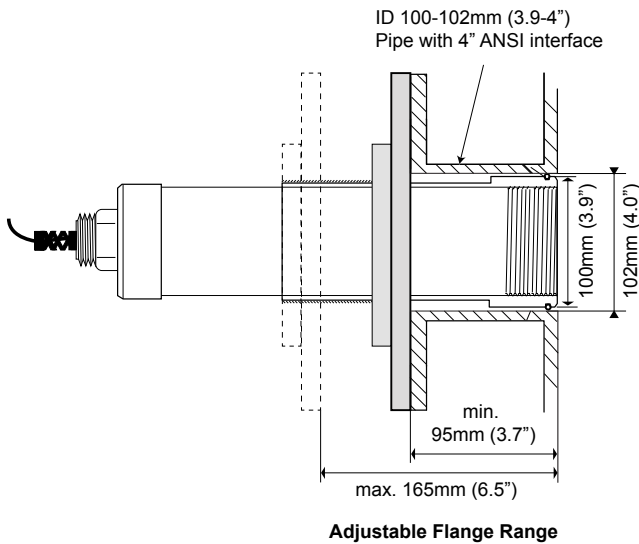

Minimum Range

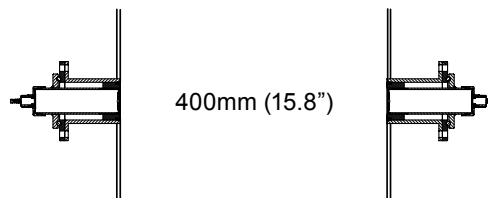



System Components

Amplifier



Junction Box

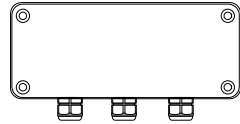

Acoustic Switch 15kHz Remote Transducers with UHMW sleeve and Flange

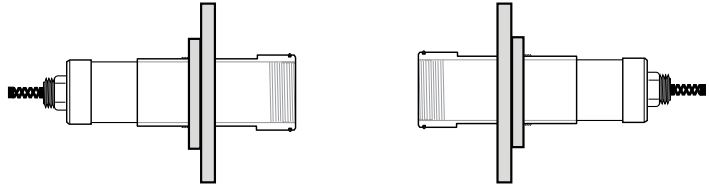

or

Acoustic Switch 15kHz Remote Transducers with Spray Sleeve and Flange

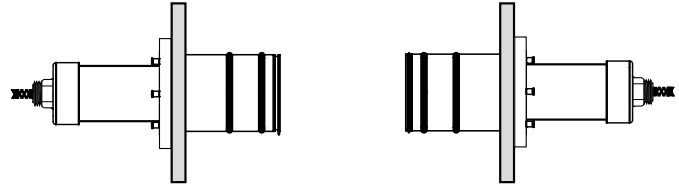

Gladiator Remote Amplifier Wiring

			SLAVE IN		MASTER OUT		RELAY 1			RELAY 2					
			TEST IN					NC	COM	NO	NC	COM	NO		
<input type="checkbox"/>	<input type="checkbox"/>	<input type="checkbox"/>	<input type="checkbox"/>	<input type="checkbox"/>	<input type="checkbox"/>	<input type="checkbox"/>	<input type="checkbox"/>	<input type="checkbox"/>	<input type="checkbox"/>	<input type="checkbox"/>	<input type="checkbox"/>	<input type="checkbox"/>	<input type="checkbox"/>	<input type="checkbox"/>	<input type="checkbox"/>
<input type="checkbox"/>	<input type="checkbox"/>	<input type="checkbox"/>	<input type="checkbox"/>	<input type="checkbox"/>	<input type="checkbox"/>	<input type="checkbox"/>	<input type="checkbox"/>	<input type="checkbox"/>	<input type="checkbox"/>	<input type="checkbox"/>	<input type="checkbox"/>	<input type="checkbox"/>	<input type="checkbox"/>	<input type="checkbox"/>	<input type="checkbox"/>
<input type="checkbox"/>	<input type="checkbox"/>	<input type="checkbox"/>	<input type="checkbox"/>	<input type="checkbox"/>	<input type="checkbox"/>	<input type="checkbox"/>	<input type="checkbox"/>	<input type="checkbox"/>	<input type="checkbox"/>	<input type="checkbox"/>	<input type="checkbox"/>	<input type="checkbox"/>	<input type="checkbox"/>	<input type="checkbox"/>	<input type="checkbox"/>
16	17	18	19	20	21	22	23	24	25	26	27	28	29	30	
1	2	3	4	5	6	7	8	9	10	11	12	13	14	15	
+	-		RED	BLACK	BLUE	WHITE			B	A	-	+	⊕	⊖	
4-20mA (N/A)			SENSOR			COMMS			DC-In			AC-In*			
												AC-In*			

Solenoid wiring for Spray Cleaner

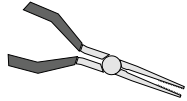
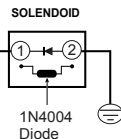

Use long nose pliers to extract terminals

Relay 1 - Output Relay
Relay 2 - FailSafe Relay

*AC-In is replaced by 36-60VDC with Power Input Option 'C'.

AWRT-JB-01 Junction Box

Connect colour to colour

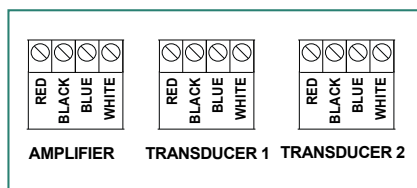

System Overview

Gladiator Acoustic Switch Series



GAWC-SYS1 Acoustic Cleaner Components

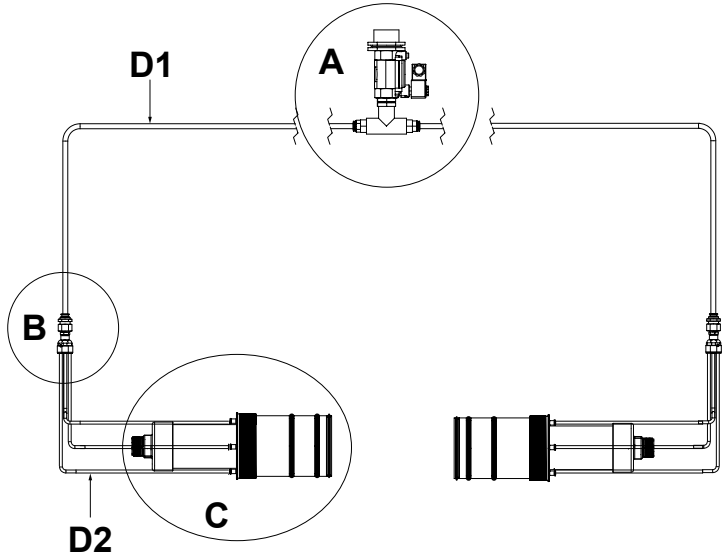

Note: Full cleaner package **GAWC-SYS1** includes all converters, reducers, connectors, 30m of 12mm tube, 20m of 6mm tube, solenoid and FA4A-4-ASC flanges. It does not include other electronics (transducers, amplifier, junction box).

	Part Description	Part Number
A	Solenoid	GAWC-SL
B	0.5" to 4 x 1/4" connector	GAWC-4P
C1	Hawk Transducer	AWRT15_____AS*
C2	Cleaner Sub-assembly	GAWC-X
D1	Ø 12mm tube Supplied in single piece Total length = distance of part A to part B x 2 (one length per transducer)	GAWC-12MMLz
D2	Ø 6mm tube Supplied in single piece Total length = distance of part B to part C x 8 (Four equal lengths per transducer)	GAWC-06MMLz

z = Specify length in metres

*Consult Acoustic Switch datasheet for full transducer part numbering

Detail A

1" BSP INT THD on Solenoid
Water connection size
determined by end user

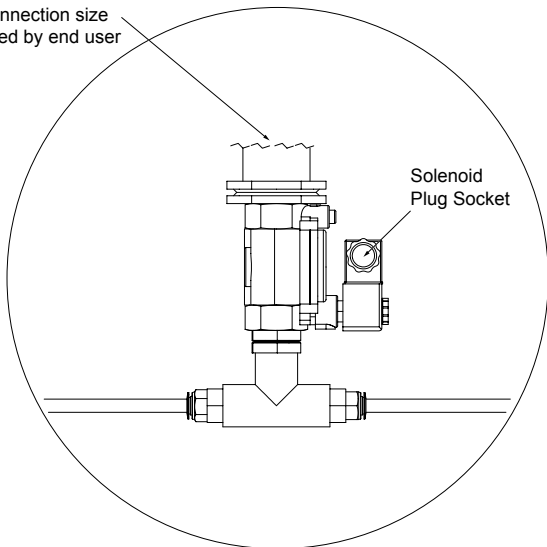

Detail B

D1

Ø12mm Tube

D2

Ø6mm Tube

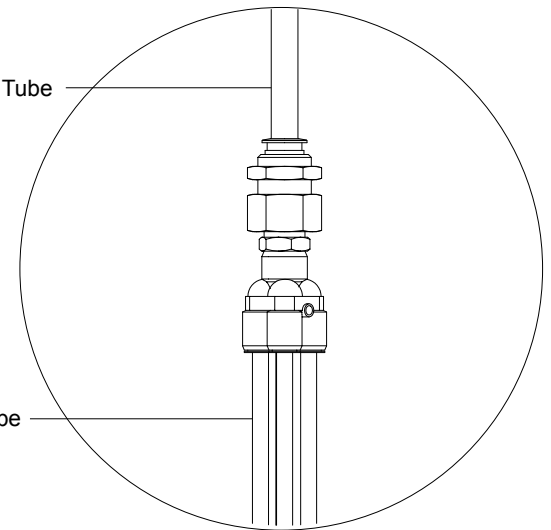

Detail C

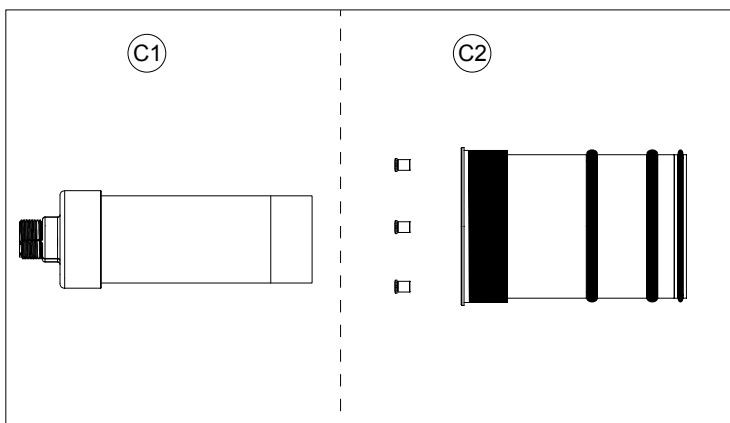

Max. water pressure 14bar (1400kpa)
Min. water pressure 1bar (100kpa)

Wiring Diagram for Solenoid Plug Socket
1N4004 Diode

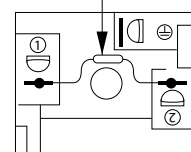

System Overview

Gladiator Acoustic Switch Series



GAWC-SYS2 Acoustic Cleaner Components

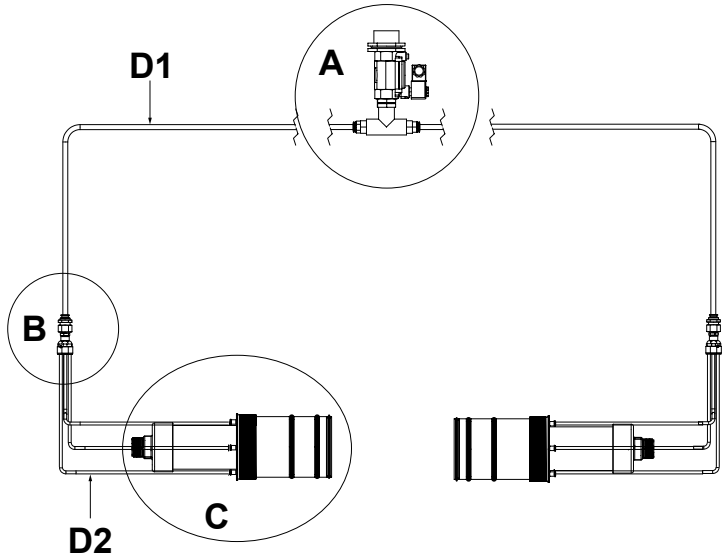

Note: Full cleaner package **GAWC-SYS2** includes all converters, reducers, connectors, 30m of 12mm tube, 20m of 6mm tube, solenoid and FA4A-4-ASC flanges. It does not include other electronics (transducers, amplifier, junction box).

	Part Description	Part Number
A	Heavy Duty Burkett Valve & Solenoid	GAWC-SL2
B	0.5" to 4 x 1/4" connector	GAWC-4P
C1	Hawk Transducer	AWRT15_____AS
C2	Cleaner Sub-assembly	GAWC-X
D1	Ø 12mm tube Supplied in single piece Total length = distance of part A to part B x 2 (one length per transducer)	GAWC-12MMLz
D2	Ø 6mm tube Supplied in single piece Total length = distance of part B to part C x 8 (Four equal lengths per transducer)	GAWC-06MMLz

z = Specify length in metres

Detail A

1" BSP INT THD on Solenoid
Water connection size
determined by end user

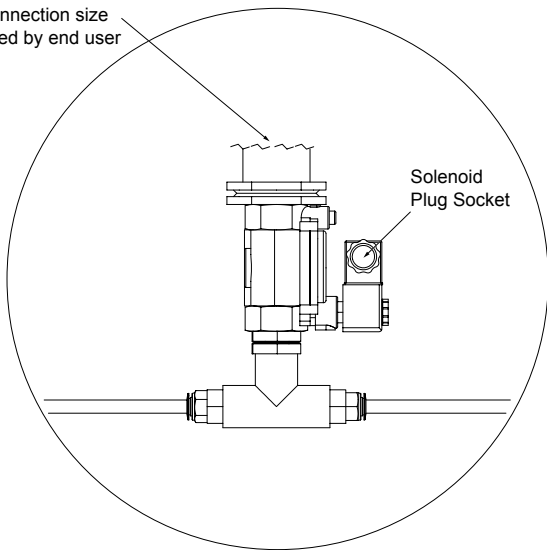

Detail B

D1

Ø12mm Tube

D2

Ø6mm Tube

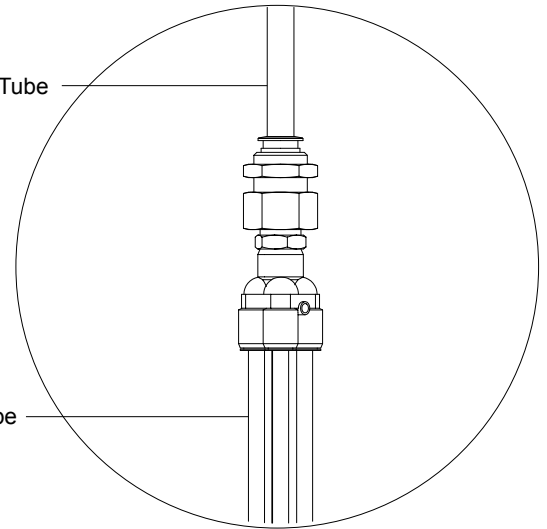

Detail C

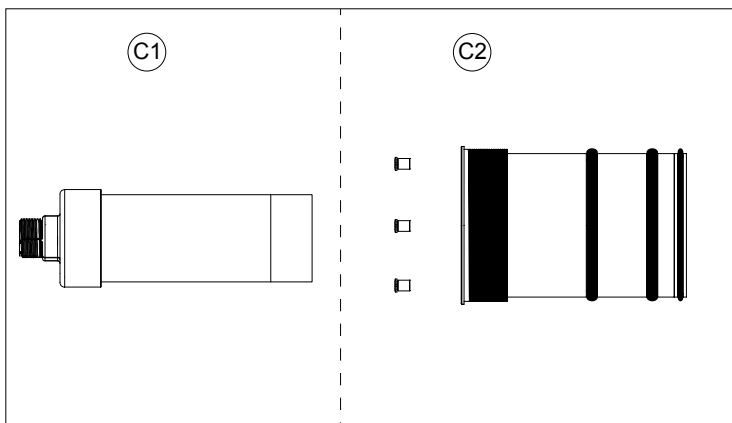

Max. water pressure 16bar (1600kpa)
Min. water pressure 1bar (100kpa)

Wiring Diagram for Solenoid Plug Socket
1N4004 Diode

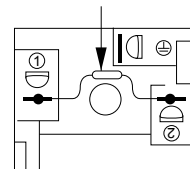

Part Numbering

Gladiator Acoustic Switch Series



Remote Amplifier

- GSA** Remote Gladiator System Amplifier
- Housing**
- S Standard polycarbonate electronics housing
- Power Supply**
- B 12-30VDC
 - C 36-60VDC
 - U 12-30VDC and 90-260VAC

- Output Options**
- S Switch. 1 level relay, 1 failsafe relay, with Modbus

- Other Options**
- A22 ATEX Grp II Cat 3 GD T85°C IP67 Tamb -40°C to 70°C

GSA S U S

Mounting Flange

- FA4A-4** HAWK 4" ANSI flange with decoupled connection flange for acoustic switch sleeve
- FA4A-4-ASC** HAWK 4" ANSI flange with decoupled connection flange for spray cleaner sleeve

Remote Transducer

- AWRT** **Acoustic Wave Remote Transducer**
- 15 15kHz for applications with heavy duty self cleaning requirements
- Transducer Diaphragm / Sleeve Material**
- T Teflon / UHMW (applications suitable for Teflon (no sensor face wear))
 - Y Titanium face / UHMW (applications with possible sensor face wear eg crushers)
- Transducer Housing Material**
- 4 Polypropylene
- Thread Standards for End cap**
- X Not Available
- Mounting Thread**
- X 15kHz - GAWSLV-3-X sleeve mounted (3.5" BSP thread to suit FA4A-4 flange)
- Approval Standard**
- X Not Required
 - A22 ATEX Grp II Cat 3 GD T85°C IP67 Tamb -40°C to 70°C
- Connection**
- C IP68 Sealed unit with cable
- Cable Length**
- 15 15m cable (standard)
 - 30 30m cable
- Accessories**
- X UHMW sleeve
- Software Options**
- AS Gladiator Acoustic Switch

AWRT 15 Y 4 X X X C 15 X AS

Junction Box

- AWRT-JB-01** HAWK multi purpose junction box for dual transducer applications
- AWRT-JB-06** HAWK multi purpose junction box for dual transducer applications with 6m cable

Extra Cable (Length in metres)

- CA-TXCC-R-**
- C15
 - C30
 - C50
 - C100

Hazardous area approvals and intrinsically safe options available, contact your local distributor or head sales office for further information.

Part Numbering

Gladiator Acoustic Switch Series



Cleaning System (GAWC-SYS1)

GAWC-SYS1 cleaner package consists of

- GAWC-X
- GAWC-SL
- GAWC-4P
- GAWC-12MML^Z
- GAWC-06MML^Z

Cleaning System Mounting Flange

FA4A-4-ASC

Water Pressure

- Minimum: 1bar (100kpa)
- Maximum: 14bar (1400kpa) (GAWC-SYS1 with Festo valve)
- Maximum: 16bar (1600kpa) (GAWC-SYS2 with Burkett valve).

Water Quality

- System requires good water quality. Install filter if required.

Water Usage

- Approximately 200ml per second per transducer (water pressure dependent).

Cleaning System (GAWC-SYS2)

GAWC-SYS2 cleaner package consists of

- GAWC-X
- GAWC-SL2
- GAWC-4P
- GAWC-12MML^Z
- GAWC-06MML^Z

Z = specify pipe length in metres

See 'GAWC-SYS1 or 2 Acoustic Cleaner Components' for length requirements

Solenoid coil MD-2-24VDC-PC - #549903

Feature	Values
Assembly position	Any
Switching position indicator	No
Duty cycle	100%
Characteristic coil data	24V DC: 6,8W
Permissible voltage fluctuation	+/- 10%
Protection class	IP65
Ambient temperature	-20...50°C
Max. tightening torque for fitting	0.5 Nm
Product weight	110 g
Electrical connection	Per DIN EN 175301-803
Mounting type	With knurled nut
Material information, solenoid coil	Duroplast Copper Steel
Material information, coil	Copper

Specifications

Gladiator Acoustic Switch Series



Operating Voltage

- 12-30VDC (residual ripple no greater than 100mV)
- 90-260VAC
- 36-60VDC.

Power Consumption

- <0.8W @ 24VDC
- <6W @ 48VDC
- <5VA @ 240VAC
- <3VA @ 115VAC.

Communications

- GosHawk, Modbus
- Multidrop mode can address 1-250 units over 4 wires.

Relay Outputs: (2) Remote

- Form 'C' (SPDT) contacts, rated 5A at 240VAC resistive
- Remote fail-safe test facility for one relay.

Operating Temperature

- Remote Electronics -40°C (-40°F) to 80°C (176°F)
- Remote Transducers -20°C (-4°F) to 80°C (176°F).

Fail-Safe

- Selectable - presence or absence of material
- High level fail-safe:
Relay is activated when material is present.
- Low level fail-safe:
Relay is activated when no material is present.

Maximum Range

- Blocked Chutes:
Maximum: 15m (50ft)
Minimum: 400mm (32").

Transducer to Amplifier Separation

- Up to 500m (1640ft) using specified extension cable (Belden 3084A).

Maximum Operating Pressure

- 2 BAR.

Display

- 2 line x 12 character alphanumeric LCD
- Backlight standard.

Memory - Remote

- Non-Volatile (No backup battery required)
- >10 years data retention.

Enclosure Sealing

- Remote Electronics IP67 (NEMA 4x)
- Remote Sensors IP68
- Junction Box IP67.

Cable Entries

- Remote Sensors
- 1 x M20 Gland / 3/4" NPTF threaded adaptor.

- Remote Amplifier
- 4 x 20mm (0.8"), 1 x 16mm (0.6") knock outs.

Mounting

- 15kHz Blocked Chute
- Transducer 4" ANSI flange with decoupled thread piece
 - Remote Amplifier Back mount, DIN rail mount
 - Pipe Specification: 4-00" Z40 ID = 100mm Black Pipe.

Typical Weight	kg	lb
----------------	----	----

- | | | |
|--------------------|---|------|
| • 15kHz Transducer | 8 | 17.6 |
| • Remote Amplifier | 1 | 2.2 |

**Hawk Measurement Systems
(Head Office)**
15 - 17 Maurice Court
Nunawading VIC 3131, AUSTRALIA

Phone: +61 3 9873 4750
Fax: +61 3 9873 4538
info@hawk.com.au

For more information and global representatives: www.hawkmeasure.com

Additional product warranty and application guarantees upon request.
Technical data subject to change without notice.

Hawk Measurement
90 Glenn Street
Suite 100B, Lawrence, MA 01843, USA
Phone: +1 888 HAWKLEVEL (1-888-429-5538)
Phone: +1 978 304 3000
Fax: +1 978 304 1462
info@hawkmeasure.com

Represented by:

