

A Higher Level of Performance



Data Sheet

ORCA

Sonar System

Sludge and Settling Level Interface Monitoring



For more information, please visit >
www.hawkmeasurement.com

Overview

ORCA Sonar System

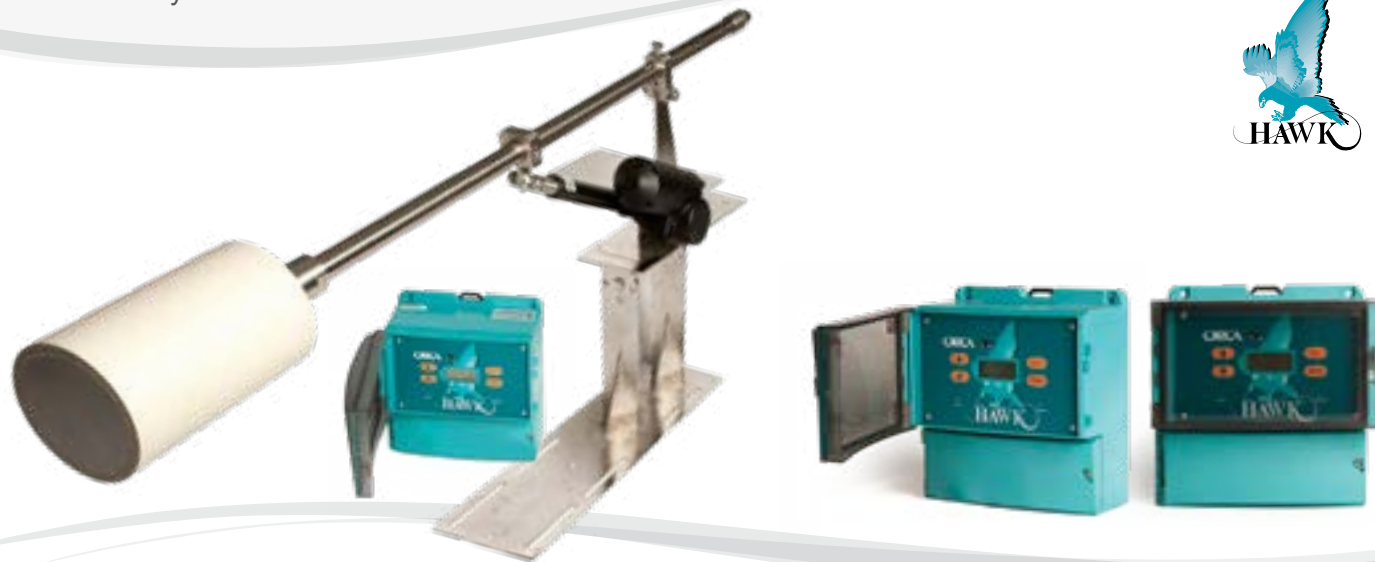

Principle of Operation

The ORCA Sonar Series transducer emits a high powered low frequency pulse, which is reflected from the interface density selected.

The reflected signal is processed using specially developed software algorithms, that eliminate lighter floating densities and stratified layers, allowing measurement of Bed or RAS levels. It can be calibrated to measure lighter densities such as the hindered / free settling layer & floc or one of the outputs could be used for a "Clarity" output, similar to a basic turbidity transmitter measuring solids in suspension.

Function

The ORCA Series Sonar, sludge blanket and interface controller, consists of a microprocessor based transmitter, with easy menu driven programming via keypad, PC or 3G modem. The ORCA controller works together with appropriate sonar transducer and transducer cleaning mechanism.

Primary Areas of Application

Mining / Process:

- Concentrate Thickeners
- Tailings Thickeners
- Hi-Rate Thickeners
- Paste Thickeners
- Deep Cone Thickeners
- Thickeners
- CCD's
- Settling Ponds / Lagoons
- Water Treatment
- Carbon Columns.

Features

- Dual independent analogue outputs to track two different interfaces, or clarity simultaneously, with the one sonar sensor
- Easy calibration to track specific density interfaces, eg: floc / fluff layer - 1g/l, Bed 10g/l+
- Industrial scum cleaning mechanisms, that do not require maintenance
- No wiper blade assemblies
- Control room graphics of tanks and interfaces via GosHawk II
- Wide range of communications: Modbus, HART, Foundation Fieldbus, DeviceNet, Profibus DP and Profibus PA
- 3G remote support capability for calibration, commissioning or technical back-up
- 3 programmable relays.



Technological Breakthrough for ORCA Sonar Transducer Range

HAWK has released the “fourth generation” sonar transducers, designed to increase the overall power, penetration and calibration density range of thickeners and CCD’s. HAWK has recognized that when monitoring thickeners and CCD’s, further penetration of the Bed level interface was necessary, to provide a wider density calibration range for the sonar transmitter.

The ORCA sonar transducer will allow the following improved capability in Thickeners and CCD’s when monitoring Bed level.

1. Greater penetration through the clarified level & the free settling zone
2. Penetration into the hindered settling zone dependent on frequency
3. The compacted zone can also be monitored using the second analogue output or one of the communication options.

The ORCA sonar transmitter can monitor two (2) different densities from one sonar transducer simultaneously - typically bed level and the hindered / settling density to be targeted with chemical dosing.

Mining Thickeners

Typical Bed Level Control

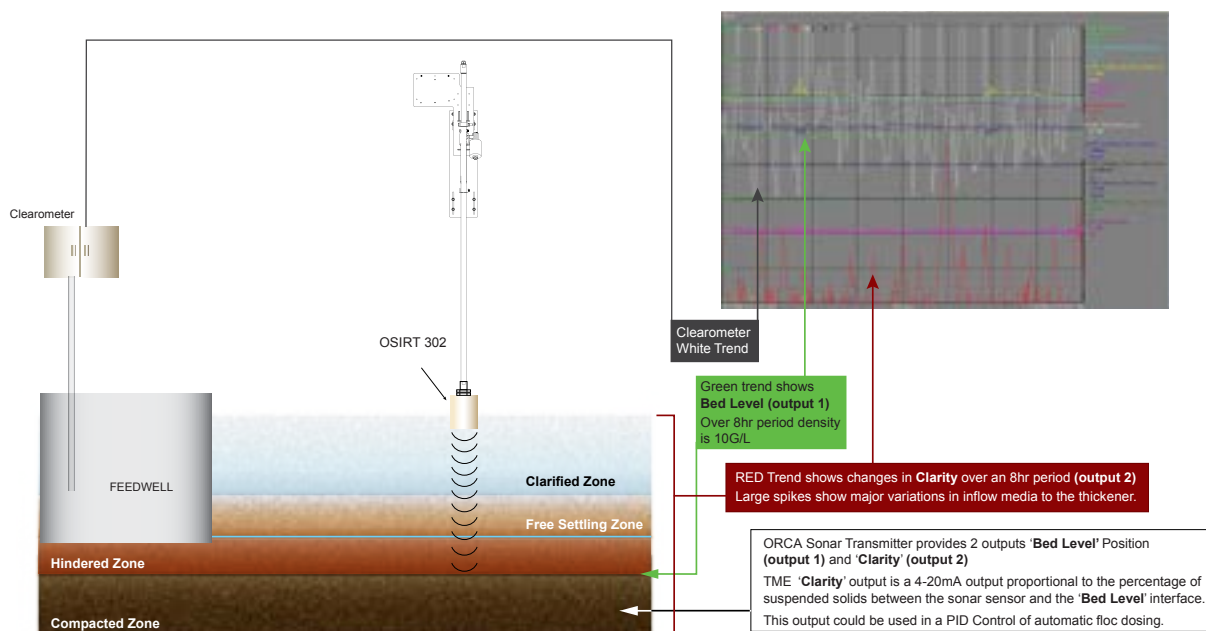

Typical Applications

Area	Functions
Mining / Mineral processing	
Clarifier Tank	Blanket level / clarity suspended solids / stratified floc layers
Thickener Tank	Sludge bed level / clarity suspended solids / stratified floc layers
CCD's Tank	Sludge bed level / clarity suspended solids / stratified floc layers
Settling Ponds	Sludge bed level
Industrial (food, paper etc.)	
Primary Sedimentation Tank	Sludge blanket level
Secondary Clarifier Tank	RAS blanket level / clarity suspended solids / rag / pin floc layer
Thickener Tank	Sludge bed level / clarity suspended solids / floc level
“DAF” Tank	Sludge bed level / floating sludge level
Sequential Batch Reactor (SBR)	Settling blanket level / RAS bed level
Carbon Column	Carbon bed level

Dimensions

ORCA Sonar System



Sonar Impact Plate

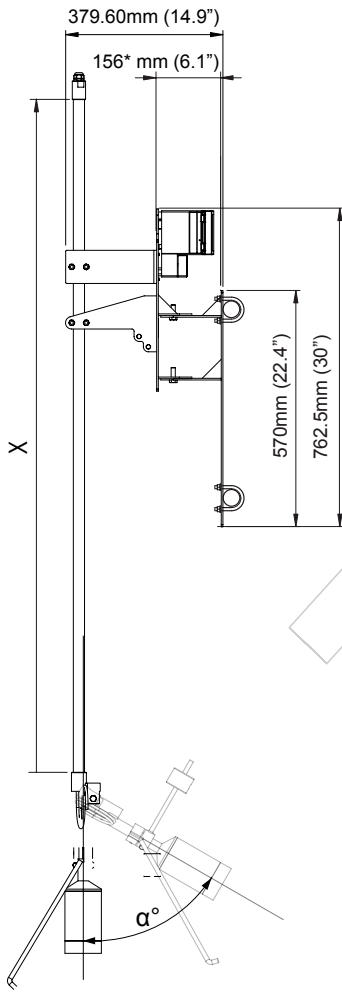

Sonar Actuator Cleaner

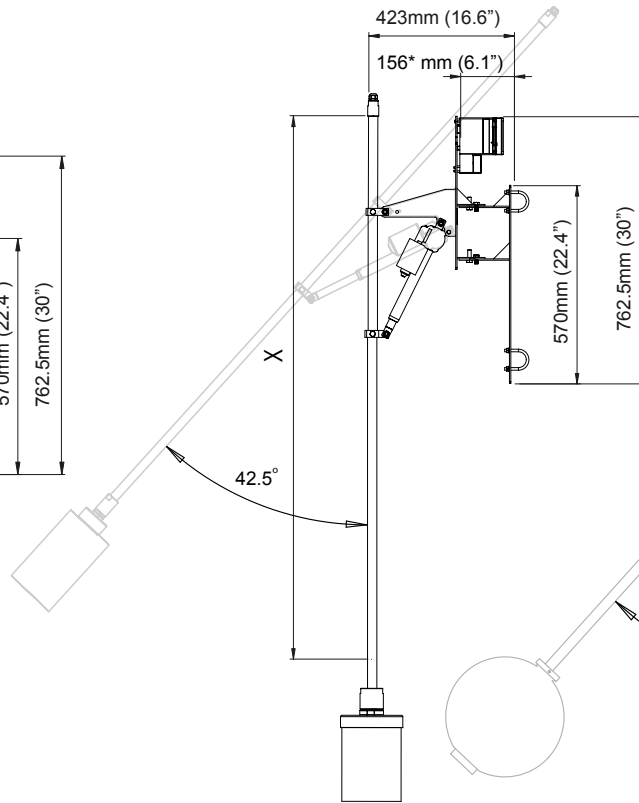

Floating Sonar Sensor

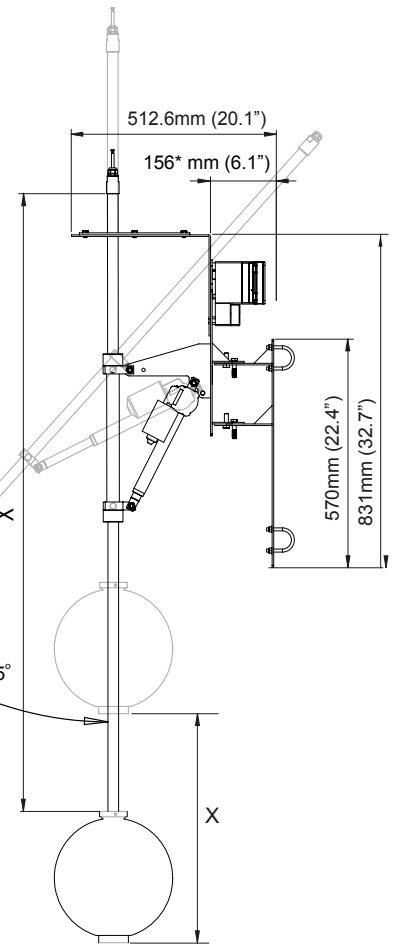

X = Decent Range
Distance from safety
rail or Bridge may vary

OSIRT 302 Transducer

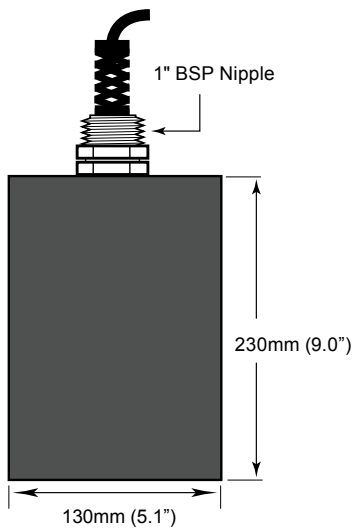

Dimensions

ORCA Sonar System



Remote Enclosure

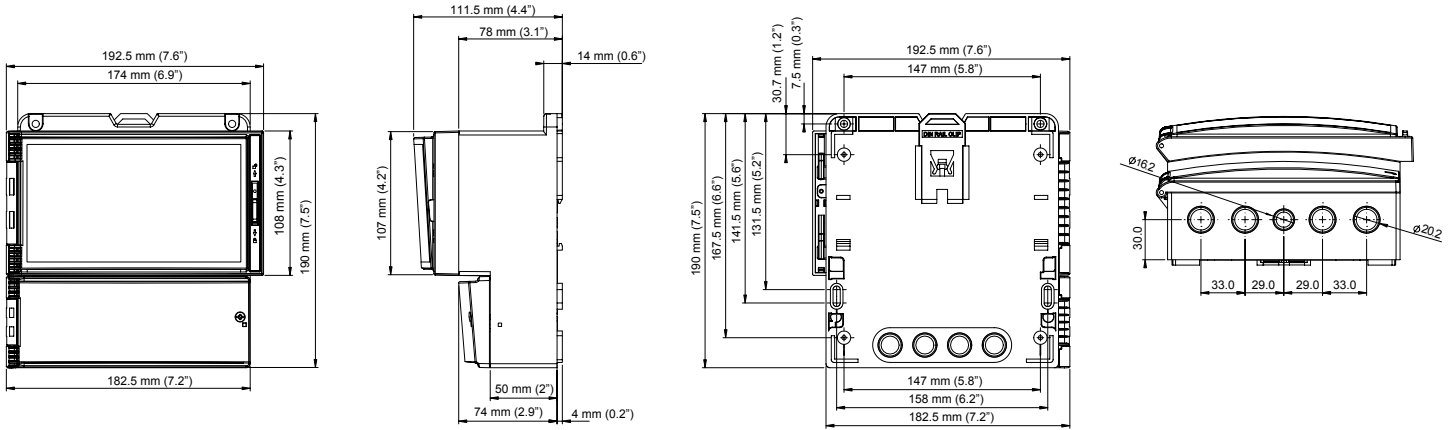

Rail Base Plate

ORCA Remote Wiring

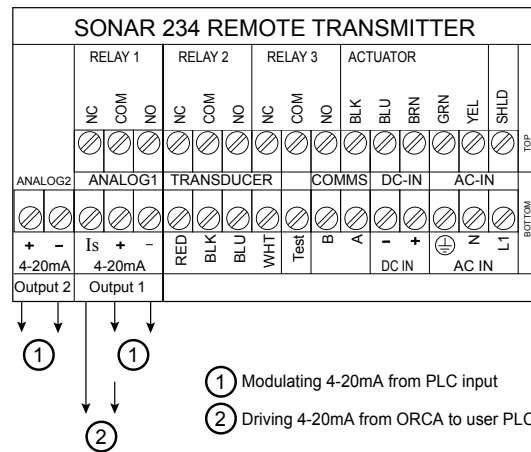
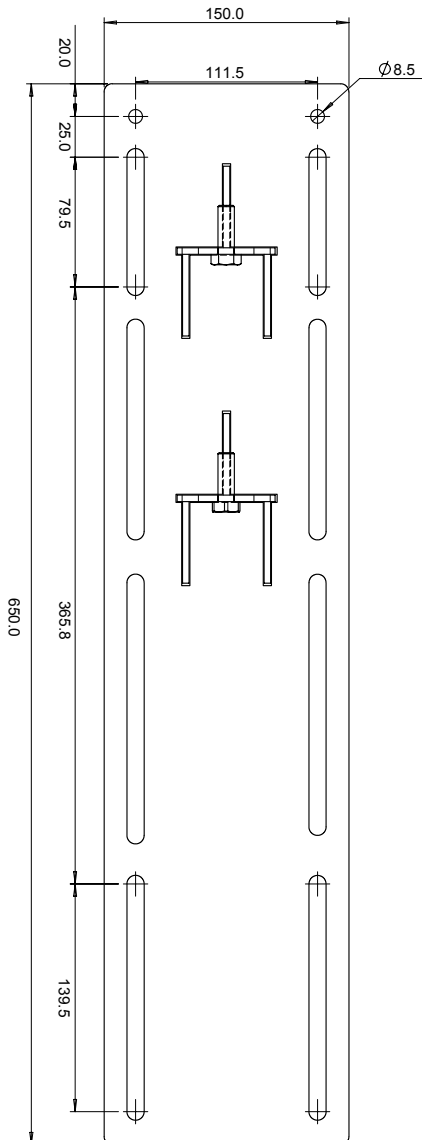

Consult user manual for additional dimensional & wiring options



ORCA Remote Electronics

OSIR Sonar Level Transmitter, 3 relay alarms, Modbus

Power Supply

- B 24-30 VDC
- D 90-250VAC and 24-30VDC

Additional Communications

- X 1 x 4-20mA
- Y 2 x 4-20mA
- I 1 x 4-20mA, HART
- J 2 x 4-20mA, HART
- E 2 x 4-20mA with Modbus over Ethernet
- B 2 x 4-20mA with Modbus over Bluetooth
- R 2 x 4-20mA with Modbus over Wi-Fi
- P Profibus DP
- A Profibus PA
- F Foundation Fieldbus
- D DeviceNet
- X This field is intentionally left blank

OSIR D Y X

Remote Sonar Transducer

OSIRT ORCA Sonar Transducer¹

Transducer Strength

- 3 Industrial / Mining

Transducer Frequency

- 02 (150kHz)

Facing & Housing material*

- SH Full fiberglass high temperature version (max. 80°C 180°F)

Approval Standard

- X Not Required

Connection

- C IP68 Sealed with cable
 - 6 6m cable
 - 15 15m cable
 - 30 30m cable
 - 50 50m cable
- FRP Full transducer / pole FRP fiberglass encapsulation (requires OSIRMELxH) consult factory

OSIRT 3 02 SH X C 6

¹ORCA Remote Electronics are fully compatible with Sultan Sonar Transducer models for lighter interface measurement with higher frequencies.

Consult Sultan Sonar datasheet for more information.

Mounting Extension Pipe

Mounting Extension

OSIRMEL Mounting Extension Stainless Steel Pipe

Length

- 2 2 meters
- 3 3 meters
- 4 4 meters
- 5 5 meters

- H Full transducer / pole FRP fiberglass encapsulation (consult factory)

OSIRMEL 2

Automatic Scum Cleaner

OSIRSC Automatic Scum Cleaner

Type

- A Electric Actuator plus Mounting Bracket Kit
- D Floating Sonar. Electric Actuator plus Mounting Bracket Kit and Float
- E Impact Plate Dual Direction plus Mounting Bracket Kit
- S Jet spray cleaner kit with solenoid
- K Jet spray cleaner kit with solenoid plus Mounting Bracket Kit
- G Mounting Bracket Kit only

OSIRSC A



CSA Approved Remote Sonar Transducer

AWRTSH ORCA Sonar Transducer

Transducer Strength

3 Industrial / Mining

Transducer Frequency

02 (150kHz)

Facing & Housing material

SH Full fiberglass high temperature version
(max. 80°C 180°F)

Approval Standard

RN CSA Class I; Div 1/2; Group D; Zone 0; AEx/Ex ia IIA; T4

Connection

C IP68 Sealed with cable

6 6m cable

15 15m cable

30 30m cable

50 50m cable

XXXX Not Required

AWRTSH 3 02 SH RN C 6 XXXX

Accessories / Parts

HAWKLINK USB PC connector for GosHawkII

HAWKLINK-USB

Stainless Steel Sunhood

SUNHOOD

Extra Cable (Belden 3084A)

CA-TXCC-R-C15 15m cable

CA-TXCC-R-C30 30m cable

CA-TXCC-R-C50 50m cable

CA-TXCC-R-C100 100m cable

Mounting Pipe - Transducer connection adapter

ADP-SS-SA-TC

Typical Complete System

- | | |
|--------------------------|---|
| 1 x OSIRDYX | Remote Transmitter |
| 1 x OSIRT302SHXC6 | Remote Transducer |
| 1 x OSIRSCA | Auto Scum Cleaner with Mounting Bracket Kit |
| 1 x OSIRMEL3 | Mounting Extension Pipe |

Specifications

ORCA Sonar System



Sonar Frequency Selection

- 150kHz

Operating Voltage

- 90 - 260Vac 50 / 60Hz
- 24Vdc (min. 5A supply)
- Residual ripple no greater than 100mV.

Power Consumption

- <10VA @ 240Vac
- <10W @ 24Vdc.

Analogue Output

- Either single or dual analogue
- 1 x 4-20mA (isolated) 600 ohms max.
- 1 x 4-20mA (non isolated) 600 ohms max.

Communications

- GosHawk, HART, Modbus, Profibus DP, DeviceNet, Foundation Fieldbus, Profibus PA.

Relay Output

- 3 x s.p.d.t. 0.5amp / 240vac
- Form c. type non-inductive load
- Fully programmable.

Maximum Range

- 25 meters.

Blanking Distance

- 450mm: 150kHz.

Resolution

- 1mm.

Accuracy

- +/- 0.25%

Operating Temperature

- Remote Electronics: -40°C to 70°C
- Sonar Transducer FRP Fibreglass: -40°C to 80°C.
- Electronic Actuator: 0°C to 80°C (recommend cover / heating for sub zero environments).

Transducer / Transmitter Separation

- >500m

Note: Must be BELDEN 3084A

Actuator / Transmitter Separation

- Consult ORCA Manual for wiring information

Cable (Sonar Transducer)

- BELDEN 3084A.

Sealing

- Remote Electronics IP67
- Remote Transducer IP68.

Cable Entries

- Remote Electronics: 3 x 20mm 1 x 16mm.

Typical Weight

- Remote Electronics 1kg
- Remote Transducer 1kg
- Cleaning Mechanism 5kg.

Hawk Measurement Systems (Head Office)

15 - 17 Maurice Court
Nunawading VIC 3131, AUSTRALIA

Phone: +61 3 9873 4750

Fax: +61 3 9873 4538

info@hawk.com.au

For more information and global representatives: www.hawkmeasurement.com

Additional product warranty and application guarantees upon request.

Technical data subject to change without notice.

Hawk Measurement

5010 Gateway Drive, Medina, OH 44256, USA

Phone: +1 888 HAWKLEVEL (1-888-429-5538)

Phone: +1 978 304 3000 / +1 877-356-5463

Fax: +1 978 304 1462 / +1 330-331-7172

info@hawkmeasure.com